

FEMTO D4 DC VDC

INSTALLATION INSTRUCTIONS

COPYRIGHT

Electrex is a trademark of Akse S.r.l. All rights reserved.
It is forbidden to duplicate, adapt, transcript this document without Akse written authorization, except when regulated accordingly by the Copyright Laws.

WARRANTY

This product is covered by a warranty against material and manufacturing defects for a 24 months period from the manufacturing date.

The warranty does not cover the defects that are due to:

- Negligent and improper use
- Failures caused by atmospheric hazards
- Acts of vandalism
- Wear out of materials
- Firmware upgrades

Akse reserves the right, at its discretion, to repair or substitute the faulty products

The warranty is not applicable to the products that will result defective in consequence of a negligent and improper use or an operating procedure not contemplated in this manual.

RETURN AND REPAIR FORMALITIES

Akse accepts the return of instruments for repair only when authorized in advance. The transport costs are at customer charge.

RE-SHIPING OF REPAIRED PRODUCT

The terms for re-shipment of repaired products are ex-works, i.e. the transport costs are at customer charge.

Products returned as defective but found to be perfectly working by our laboratories, will be charged a flat fee to account for checking and testing time irrespective of the warranty terms.

SAFETY

This instrument was manufactured and tested in compliance with IEC 61010-1 CAT III-300V class 2 standards for exercise voltages up to 300 Vac rms phase to neutral.

In order to maintain this condition and to ensure safe operation, the user must comply with the indications and markings contained in the following instructions:

- When the instrument is received, before starting its installation, check that it is intact and no damage occurred during transport.
- Before mounting, ensure that the instrument operating voltages and the mains voltage are compatible then proceed with the installation.
- The instrument power supply needs no earth connection.
- The instrument is not equipped with a power supply fuse; a suitable external protection fuse must be foreseen by the contractor.
- Maintenance and/or repair must be carried out only by qualified, authorized personnel
- If there is ever the suspicion that safe operation is no longer possible, the instrument must be taken out of service and precautions taken against its accidental use.
- Operation is no longer safe when:
 - 1) There is clearly visible damage.
 - 2) The instrument no longer functions.
 - 3) After lengthy storage in unfavorable conditions.
 - 4) After serious damage occurred during transport



The instruments must be installed in respect of all the local regulations.

OPERATOR SAFETY

Warning: Failure to observe the following instructions may lead to a serious danger of death.

- During normal operation dangerous voltages can occur on instrument terminals and on voltage and current transformers. Energized voltage and current transformers may generate lethal voltages. Follow carefully the standard safety precautions while carrying out any installation or service operation.
- The terminals of the instrument must not be accessible by the user after the installation. The user should only be allowed to access the instrument front panel where the display is located.
- Do not use the digital outputs for protection functions nor for power limitation functions. The instrument is suitable only for secondary protection functions.
- The instrument must be protected by a breaking device capable of interrupting both the power supply and the measurement terminals. It must be easily reachable by the operator and well identified as instrument cut-off device.
- The instrument and its connections must be carefully protected against short-circuit.

Precautions: Failure to respect the following instructions may irreversibly damage to the instrument.

- The instrument is equipped with PTC current limiting device but a suitable external protection fuse should be foreseen by the contractor.
- The outputs and the options operate at low voltage level; they cannot be powered by any unspecified external voltage.
- The application of currents not compatible with the current inputs levels will damage to the instrument.

Further documentation may be downloaded from our web site www.electrex.it.

This document is owned by the company AKSE that reserves all rights.

DECLARATION OF CONFORMITY

Akse hereby declares that its range of products complies with the following directives EMC 89/336/EEC 73/23CE 93/68 CE and complies with the following product's standard CEI EN 61326 – IEC 61326 CEI EN 61010 – IEC 61010.

The product has been tested in the typical wiring configuration and with peripherals conforming to the EMC directive and the LV directive.

Subject to modification without notice. Edition 20-05-2010

READINGS



Push for 2 seconds to display:

- Type of instrument
- Firmware version
- Serial number
- RS485 address

READINGS DISPLAYED IN THE UPPER AREA OF THE DISPLAY

(The parameters available may change according to instrument configuration)

	Ea	U	I	P
meas	Ea Imp	U	I	P
page	Ea Exp	Min U	I Max	P Avg Imp
		Max U	I Avg	P Avg Exp
			I MD	P MD Imp
				P MD Exp

U 230.0^{L1N}

READINGS DISPLAYED IN THE LOWER AREA OF THE DISPLAY

(The parameters available may change according to instrument configuration)

		Press to change type of measure	
Push for 2 seconds to display.	cnt	Ea Σ+	
		Ea Σ-	
		Ea P+	
		Ea P-	
		CNT1 Σ	
		CNT1 P	
		TIME Σ	TEMP °C
		TEMP °C	TEMP °F

E_p Σ 562319.62 kvarh
L1 →

LEGEND OF PARAMETERS AND SYMBOLS



Avg	Average (rolling) value	U	Voltage
MD	Maximum Demand	I	Current
Imp (+)	Import value	P	Active Power
Exp (-)	Export value	Ea	Active Energy
Min	Minimum values (10 cycles time base)		
Max	Maximum values (10 cycles time base)		
TIME Σ	Life Time (total)	TEMP °C	Temperature in °Celsius
TIME P	Life Time (partial)	TEMP °F	Temperature in °Fahrenheit
CNT Σ	Pulse count (total)		
CNT P	Pulse count (partial)		

MECHANICAL CHARACTERISTICS

Case	self extinguish plastic class V0
Protection degree	IP40 (front)
Size	70 x 90 x 58 mm (4 DIN modules)
VOLTAGE INPUT	
Direct	up to 300 V
	max 360 V
Power supply	18-60 VDC
Self consumption	< 3VA
MODEL	
PFA6471-18	FEMTO D4 DC RS485 18-60VDC 1DI 2DO ENERGY ANALYZER

DEVICE SETUP

OPERATING KEYS

			
Click	Change selected field value	Change selected field value	Go to next field
Click 2 sec	Go to next window	Back to initial entry field	Exits setup

ENTER INTO SET UP MODE
(Push together for 2 seconds)



SETUP LIST

PAGE	PARAMETERS	VALUES AVAILABLE	DEFAULT
PASSWORD REQUEST			
		0000 ... 9999	0000
RS485			
	RS485 Address	1 ... 247	27
	Rate	2400, 4800, 9600, 19200, 38400	38400
	Data Bit	7 or 8	8
	Parity	N = no parity, E = even parity, O = odd parity	N
	Stop Bit	1 or 2	2
<div style="border: 1px solid black; padding: 5px; width: fit-content; margin: auto;"> RS-485 ADDR 027 COM 38400-8-N-2 </div>			
NETWORK			
	Export	NO, YES	NO
	I FS	1 ... 10000	00010
	SHUNT	60 o 100	60
	VR	400000/999	1/1
<div style="border: 1px solid black; padding: 5px; width: fit-content; margin: auto;"> NETWORK EXPORT NO I FS 00010 SHUNT 60 VR 000900/300 </div>			
AVG-MD TIME (note n.1)			
	POWERS	1...60 (minutes)	15
	CURRENTS	1...60 (minutes)	8
<div style="border: 1px solid black; padding: 5px; width: fit-content; margin: auto;"> AVG-MD TIME POWERS 15 CURRENTS 08 </div>			
ALARM 1 / A (note n.10)			
	MODE (note n.2)	NORMAL, DERIV	NORMAL
	TYPE (note n.3)	MAX, MIN	MIN
	MEAS (note n.4)	Controlled measure. See table n.1 for register selection	344
	THRE (note n.4)	Threshold value	0
<div style="border: 1px solid black; padding: 5px; width: fit-content; margin: auto;"> ALARM 1/A MODE NORMAL TYPE MAX MEAS 344 THRE 000,00 </div>			
ALARM 1 / B			
	HYST	1...100 (%)	1
	DELAY	1...99 (seconds)	1
	AVG (note n.5)	1...99 (seconds)	1
	OUT (note n.6)	Normal, Hold, Pulse-L, Pulse-S	NORMAL
<div style="border: 1px solid black; padding: 5px; width: fit-content; margin: auto;"> ALARM 1/B HYST 01 DELAY 01 AVG 01 OUT NORMAL </div>			
ALARM 2 / A (note n.10)			
	MODE (note n.2)	NORMAL, DERIV	NORMAL
	TYPE (note n.3)	MAX, MIN	MIN
	MEAS (note n.4)	Controlled measure. See table n.1 for register selection	344
	THRE (note n.4)	Threshold value	0
ALARM 2 / B			
	HYST	1...100 (%)	1
	DELAY	1...99 (seconds)	1
	AVG (note n.5)	1...99 (seconds)	1
	OUT (note n.6)	Normal, Hold, Pulse-L, Pulse-S	NORMAL
ALARM 3 / A (note n.10)			
	MODE (note n.2)	NORMAL, DERIV	NORMAL
	TYPE (note n.3)	MAX, MIN	MIN
	MEAS (note n.4)	Controlled measure. See table n.1 for register selection	344
	THRE (note n.4)	Threshold value	0
ALARM 3 / B			
	HYST	1...100 (%)	1
	DELAY	1...99 (seconds)	1
	AVG (note n.5)	1...99 (seconds)	1
	OUT (note n.6)	Normal, Hold, Pulse-L, Pulse-S	NORMAL
ALARM 4 / A (note n.10)			
	MODE (note n.2)	NORMAL, DERIV	NORMAL
	TYPE (note n.3)	MAX, MIN	MIN
	MEAS (note n.4)	Controlled measure. See table n.1 for register selection	344
	THRE (note n.4)	Threshold value	0
ALARM 4 / B			
	HYST	1...100 (%)	1
	DELAY	1...99 (seconds)	1
	AVG (note n.5)	1...99 (seconds)	1
	OUT (note n.6)	Normal, Hold, Pulse-L, Pulse-S	NORMAL

DIGITAL OUT 1 (note n.7)

MODE	PULSE, ALARM, REMOTE	PULSE
POLARITY	NO, NC	NO

DIGITAL OUT 1
 MODE PULSE
 POLARITY NO

PULSE OUT 1

MEAS (note n.8)	P-IMP, P-EXP	P-IMP
PRIMARY (note n.9)	YES, NO	YES
WEIGHT	1...100000000 (Wh/100)	100000
WIDTH	50ms...1S	500

PULSE OUT 1
 MEAS P-IMP
 PRIMARY YES
 WEIGHT 100,00k
 WIDTH 0500

DIGITAL OUT 2 (note n.7)

MODE	PULSE, ALARM, REMOTE	PULSE
POLARITY	NO, NC	NO

PULSE OUT 2

MEAS (note n.8)	P-IMP, P-EXP	P-EXP
PRIMARY (note n.9)	YES, NO	YES
WEIGHT	1...100000000 (Wh/100)	100000
WIDTH	50ms...1S	500

DISPLAY

CONTRAST	20 - 45	36
CLEAR TOTAL COUNTERS	NO, YES	NO
CLEAR PARTIAL COUNTERS	NO, YES	NO
CLEAR MIN-MAX	NO, YES	NO
CLEAR MAX DEMAND	NO, YES	NO
RESTORE FACTORY SETTINGS	NO, YES	NO
ENTER NEW PASSWORD	0000 ... 9999	0000

EXIT SETUP
(push for 2 seconds)



TABLE n.1 (ModBus Registers for alarm configuration)

REGISTER	DESCRIPTION	SYMBOL	UNITS
220	Voltage Amplitude	U	[V]
232	Current Amplitude	I	[A]
240	Active Power (Imp/ Exp)	P	[W]
332	Current AVG	I AVG	[A]
344	Total imported active power, AVG	P Imp AVG	[W]
352	Total exported active power, AVG	P Exp AVG	[W]
376	External Pulse Counter, With Weight, Total counter or Tariff T1	CNT1 S	
384	External Pulse Counter, With Weight, Partial Counter or Tariff T2	CNT1 P	

Note n.1	
POWERS	Integration time of the average value (AVG) and peak value (MD) for power (from 1 to 60 minutes)
CURRENTS	Integration time of the average value (AVG) and peak value (MD) for current (from 1 to 60 minutes)
Note n.2	
NORMAL	Classic Alarm with reference to a fixed threshold or to maximum and minimum delay and applicable hysteresis. "AVG" parameter is not used.
DERIV	"THRE" parameter becomes a % value, "AVG" parameter is used. The instant value applied to the alarm on "MEAS" is compared with its value mediated obtained on the basis of the time set on "AVG". When the instantaneous value combined alarm differs in more (setting "Max") or less (setting "MIN") from the average value ("AVG") of the percentage set on "THRE" the alarm goes on. With delay and applicable hysteresis.
Note n.3	
MAX	Alarm setting in excess compared with the established conditions.
MIN	Alarm setting in decrease compared with the established conditions.
Note n.4	
MEAS	indicates which register (and thus measure) the alarm is related. See table n.1 input register.
THRE	Alarm threshold in absolute value, with the exception made for "DERIV" in which the value inserted becomes a percentage.
Note n.5	
AVG	Parameter to be used only in "DERIV" mode. Is the duration of the reference (in seconds) used to create a reference value for the instantaneous readings.
Note n.6	
NORMAL	Physical output of the alarm excited during the duration of the alarm. It restores automatically
HOLD	Output remains excited until manual reset made via Modbus
PULSE-L	Output generate a 500ms impulse when the alarm goes on.
PULSE-S	Output generate a 100ms impulse when the alarm goes on.
Note n.7	
PULSE	Enables exit function as impulsive
ALARM	Enables exit function as alarm
REMOTE	Enables function output via protocol Modbus
NO	Normally open
NC	Normally closed
Note n.8	
P-IMP	Imported Active Power (Energy)
P-EXP	Exported Active Power (Energy)
Note n.9	
YES	Referred to SHUNT primary
NO	Referred to SHUNT secondary
Note n.10	
ALARM 1	Alarm related to the physical output: DIGITAL OUT 1 (DO1, terminal 8)
ALARM 2	Alarm related to the physical output: DIGITAL OUT 2 (DO2, terminal 9)
ALARM 3	Only MODBUS alarm
ALARM 4	Only MODBUS alarm

DIGITAL INPUTS AND OUTPUTS CONNECTION

(only for the version PFA6471-12)

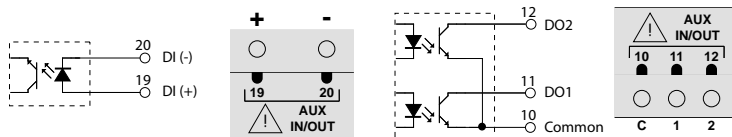

Digital Inputs	
Supply voltage (external):	from 10 to 30 Vdc
Current consumption:	from 2 to 10mA
Max. count frequency	10 or 100Hz
N.B. For gas meters a galvanic separation is needed per ATEX standards	

Digital outputs (optocoupled NPN transistor type for DIN 43864)	
Maximum applicable voltage:	27 Vdc
Maximum switchable current:	27 mA

INPUT & OUTPUTS CONNECTION EXAMPLE

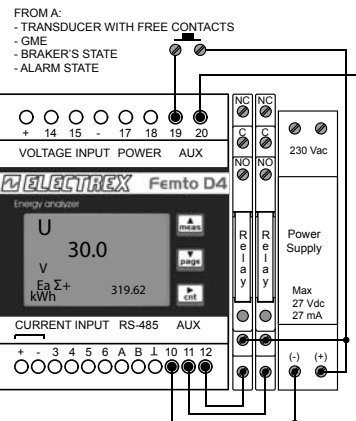
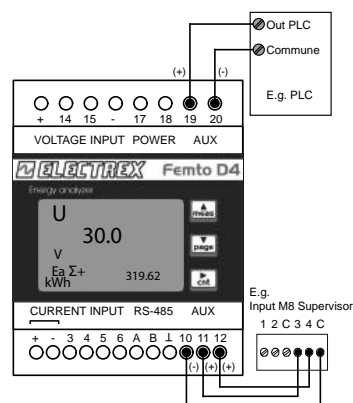

ALARM SET UP EXAMPLE

To ensure that the exit "Digital out 1" remain excited for the alarm duration (latching) when average active power (MEAS 344) exceeds the value of 100 kW, hysteresis, 5% and latency of 5 seconds set the parameters such as table:

ALARM 1 / A	MODE (note n.1)	NORMAL, DERIV	NORMAL
	TYPE (note n.2)	MAX, MIN	MAX
	MEAS (note n.3)	Controlled measure. See table n.1 for register selection	344
	THRE (note n.3)	Threshold value	100000
ALARM 1 / B	HYST	1...100 (%)	5
	DELAY	1...99 (seconds)	5
	AVG (note n.4)	1...99 (seconds)	1
	OUT (note n.5)	Normal, Hold, Pulse-L, Pulse-S	NORMAL
DIGITAL OUT 1	MODE	PULSE, ALARM, REMOTE	ALARM
	POLARITY	NO, NC	NO

To ensure that the exit "Digital out 2" remain excited for the alarm duration (latching) when average active power (MEAS 344) goes down the value of 90 kW, hysteresis, 5% and latency of 5 seconds set the parameters such as table:

ALARM 2 / A	MODE (note n.1)	NORMAL, DERIV	NORMAL
	TYPE (note n.2)	MAX, MIN	MIN
	MEAS (note n.3)	Controlled measure. See table n.1 for register selection	344
	THRE (note n.3)	Threshold value	90000
ALARM 2 / B	HYST	1...100 (%)	5
	DELAY	1...99 (seconds)	5
	AVG (note n.4)	1...99 (seconds)	1
	OUT (note n.5)	Normal, Hold, Pulse-L, Pulse-S	NORMAL
DIGITAL OUT 2	MODE	PULSE, ALARM, REMOTE	ALARM
	POLARITY	NO, NC	NO

MESSAGE "CFG ERROR"

During the set up operation a "CFG ERROR" message could appear. This means that some wrong parameters are typed. To restore the factory default settings use the following procedure (RESTORE FACTORY SETTING) seguire la seguente procedura:



WIRING FOR VOLTAGE AND CURRENT

Voltage connection:

Use cables with max cross-section of 2,5 mm² if stranded 4 mm² if rigid and connect them to the terminals marked VOLTAGE INPUT on the instrument according to the applicable diagrams that follow.

Current connection:

Use SHUNT with adequate primary and 60 o 100 mV as secondary rate. Connect the SHUNT to the terminals marked I1 (S1 e S2) (current input) according to the applicable diagrams that follow.

SHUNT CONNECTED BEFORE

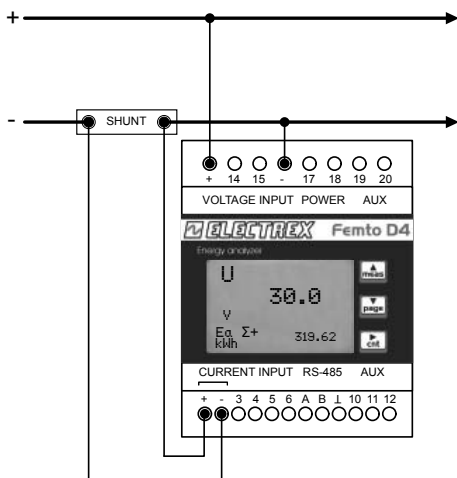

SHUNT CONNECTED AFTER

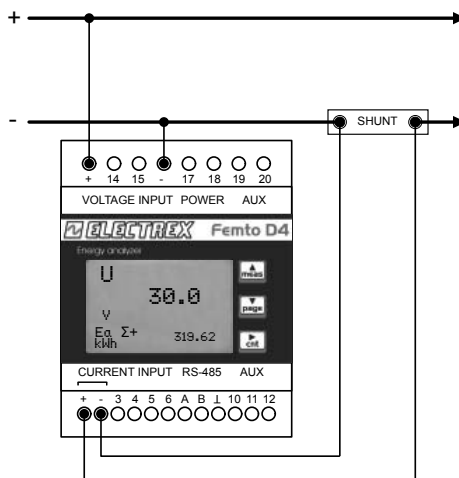

POWER SUPPLY AND SERIAL LINE CONNECTION

The instrument is fitted with a separate power supply. The power supply terminals are numbered (17) and (18). Use cables with max cross-section of 2,5 mm² if stranded, 4 mm² if rigid.

